

Fluid Cooling Industrial AOF Series

Performance Notes

- AO with removable filter
- Adjustable louvers (manual)
- Medium flow rates
- Moderate heat removal
- One or two pass option



OPTIONS
 Internal SAE straight threads
 SAE & metric connections
 Internal pressure bypass
 Corrosive resistant marine coating

Ratings

Maximum Operating Pressure
 300 PSI

Test Pressure
 300 PSI

Maximum Operating Temperature
 400°F

Materials

Tubes Copper

Fins Aluminum

Turbulators Steel

Fan Blade Aluminum with steel hub

Fan Guard Zinc plated steel

Cabinet Steel with powder coat finish

Manifolds Steel

Connections Steel

Net Weight (LBS)

Model	Weight
AOF-5	60
AOF-10	70
AOF-15	80
AOF-20	95
AOF-25	125
AOF-30	140
AOF-35	165
AOF-40	230

Piping Diagram

One Pass with Bypass

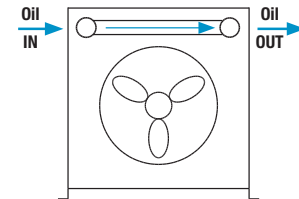

Two Pass with Bypass

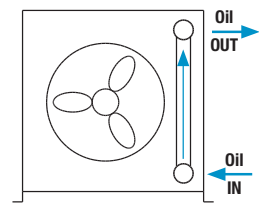

Replacement Air Filters

Model	Fiberglass Disposable Type Part Number	Aluminum Washable Type Part Number
AOF - 5	65528	65559
AOF - 10	65530	65560
AOF - 15	65507	65561
AOF - 20	65532	65562
AOF - 25	65519	65563
AOF - 30	65535	65564
AOF - 35	65537	65565
AOF - 40	65543	65566

How to Order

	-		-		-		-		-		-	
Model Series		Model Size Selected		Number of Passes*		Connection Type		Bypass Setting*		Foot Mounted Brackets		Specify Motor Required
AOF - No Relief Valve AOFR - Internal pressure bypass included				Blank - No Bypass 1 - One Pass 2 - Two Pass		Blank - NPT S - SAE M - Metric		Blank - No Bypass 30-30 - 30 PSI 60 - 60 PSI		Blank - No Brackets FB - Foot Brackets		Single Phase Single Phase Expl. Proof Three Phase Three Phase 575 Volt Three Phase Expl. Proof

***ADD FOR AOFR MODELS:** Bypass setting & number of passes.
 This is a partial flow pressure bypass only. It is not designed to be a full flow system bypass.

Dimensions

Model	A	B	C	D	E	F	G	H	J	K	L	M		N	P	Q	R	S	T
												NPT Male	SAE Female						
AOF-5	7.40	14.81	5.90	11.81	17.50	9.19	8.31	6.47	12.94	3.78	7.69	1"	#16 SAE	5.84	11.69	10.06	1.09	3.92	—
AOF-10	9.50	19.00	6.56	13.12	17.00	10.50	12.50	8.56	17.12	4.44	8.88	1"	1 1/16-12UN-2B Thread	7.94	15.88	14.38	1.09	3.92	—
AOF-15	10.19	20.38	7.87	15.75	17.62	13.12	13.88	9.25	18.50	5.75	11.50	1"		8.62	17.25	15.62	1.09	3.92	—
AOF-20	11.91	23.81	9.19	18.38	19.62	15.75	17.91	10.90	21.81	7.00	14.00	1 1/4"		10.28	20.56	18.62	1.09	3.92	—
AOF-25	13.34	26.68	11.81	23.62	20.68	21.00	20.19	12.40	24.81	9.62	19.25	1 1/4"		11.78	23.56	21.62	1.09	3.92	—
AOF-30	15.81	31.62	13.78	27.56	20.12	24.94	25.12	14.87	29.75	11.59	23.19	1 1/4"	1 1/8-12UN-2B Thread	14.25	28.50	26.62	1.09	3.92	11.00
AOF-35	16.90	33.81	15.09	30.19	21.25	27.56	27.31	15.97	31.94	12.90	25.81	1 1/4"		15.34	30.69	28.88	1.09	3.94	11.00
AOF-40	20.18	41.62	18.37	36.75	20.31	34.12	35.12	19.87	39.75	16.19	32.38	1 1/4"		19.25	38.50	37.00	1.18	3.87	13.25

NOTE: All dimensions in inches.

Piping Diagram Without Bypass

One Pass

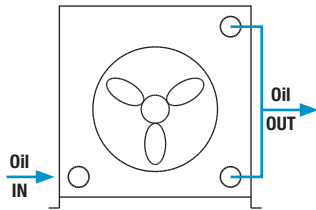

Two Pass

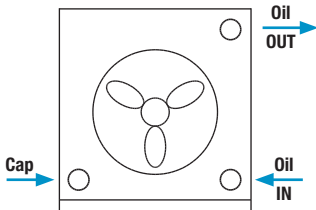

*See dimension chart for NPT or optional internal SAE connection size.

Fan Rotation Clockwise/Facing Motor Shaft

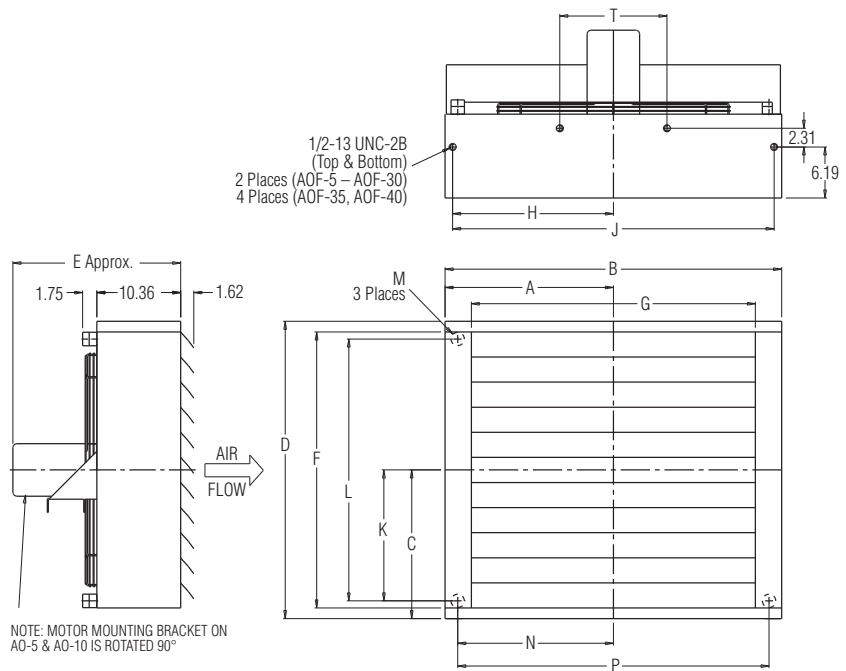

NOTE: MOTOR MOUNTING BRACKET ON AO-5 & AO-10 IS ROTATED 90°

Lubrication Notes

Caution: Do not over oil or over grease. **Ball bearings** – No grease needed at start up. Grease as follows:

5,000 Hours/Year	5 Year Grease Interval
Continuous — Normal Applications	2 Years
Seasonal Service — Motor is idle for 6 months or more	1 Year
Continuous — High ambients, dirty or moist locations, high vibration	6 Months

Performance Curves

One Pass Oil

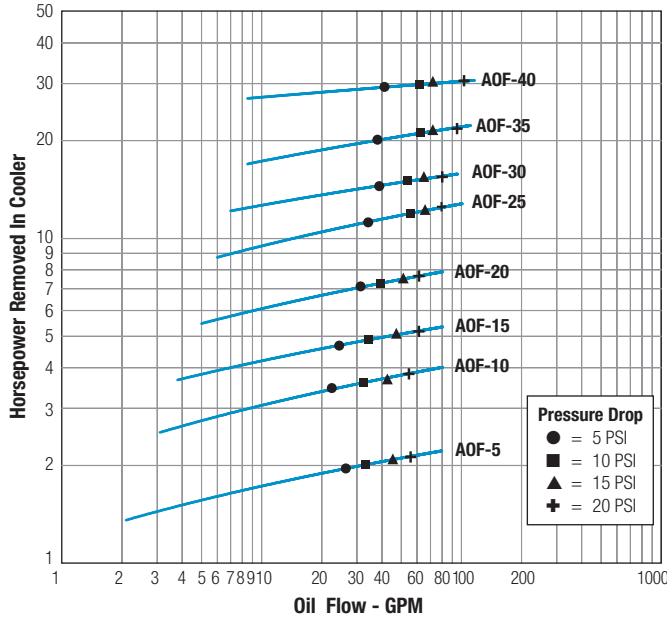

Two Pass Oil

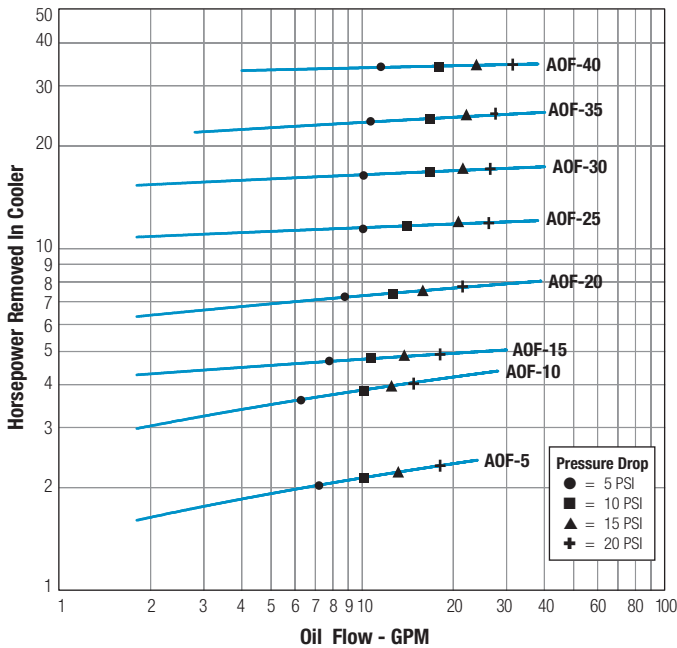

Oil Pressure Correction

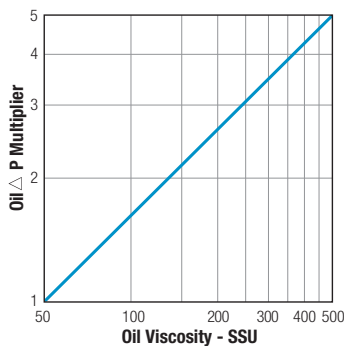

Selection Procedure

Performance Curves are based on 50SSU oil leaving the cooler 40°F higher than the ambient air temperature used for cooling. This is also referred to as a 40°F approach temperature.

STEP 1 Determine the Heat Load. This will vary with different systems, but typically coolers are sized to remove 25 to 50% of the input nameplate horsepower.

(Example: 100 HP Power Unit x .33 = 33 HP Heat load.)

$$\text{If BTU/HR is known: } \text{HP} = \frac{\text{BTU/HR}}{2545}$$

STEP 2 Determine Approach Temperature. Desired oil leaving cooler °F – Ambient air temp. °F = Actual Approach

STEP 3 Determine Curve Horsepower Heat Load. Enter the information from above:

$$\text{Horsepower heat load} \times \frac{40 \times \text{Cv}}{\text{Actual Approach}} = \text{Curve Horsepower}$$

STEP 4 Enter curves at oil flow through cooler and curve horsepower. Any curve above the intersecting point will work.

STEP 5 Determine Oil Pressure Drop from Curves:

● = 5 PSI ■ = 10 PSI ▲ = 15 PSI + = 20 PSI

Multiply pressure drop from curve by correction factor found in oil ΔP correction curve.

Desired Reservoir Temperature

Return Line Cooling: Desired temperature is the oil temperature leaving the cooler. This will be the same temperature that will be found in the reservoir.

Off-Line Recirculation Cooling Loop: Desired temperature is the oil temperature entering the cooler. In this case, the oil temperature change must be determined so that the actual oil leaving temperature can be found. Calculate the oil temperature change (oil ΔT) with this formula:

$$\text{Oil } \Delta T = (\text{BTU's/HR}) / (\text{GPM Oil Flow} \times 210)$$

To calculate the oil leaving temperature from the cooler, use this formula:

$$\text{Oil Leaving Temp.} = \text{Oil Entering Temp.} - \text{Oil } \Delta T$$

This formula may also be used in any application where the only temperature available is the entering oil temperature.

Oil Pressure Drop: Most systems can tolerate a pressure drop through the heat exchanger of 20 to 30 PSI. Excessive pressure drop should be avoided. Care should be taken to limit pressure drop to 5 PSI or less for case drain applications where high back pressure may damage the pump shaft seals.

Oil Temperature

Typical operating temperature ranges are:

Hydraulic Motor Oil	110° - 130°F
Hydrostatic Drive Oil	130° - 180°F
Bearing Lube Oil	120° - 160°F
Lube Oil Circuits	110° - 130°F

Specifications

Electric motor & Fan data*

Model	CFM	Sound dB(A)* at 7 FT	HP	Volts	Phase	Full Load Amps	HZ	Nema Frame	RPM	Type	Circuit	Thermal Overload	Bearing B-Ball
AOF-5	465	68	1/6	115/208-230	1	4./2.1-2	60	48	1725	TEFC	C	No	B
	494	70	1/4	208-230/460	3	1.4-1.3/.65	60	48	1725	TEFC	D	No	B
AOF-10	669	68	1/6	115/208-230	1	4./2.1-2	60	48	1725	TEFC	C	No	B
	710	70	1/4	208-230/460	3	1.4-1.3/.65	60	48	1725	TEFC	D	No	B
AOF-15	956	69	1/4	115/208-230	1	5.8/3-2.9	60	48	1725	TEFC	C	No	B
	1015	71	1/4	208-230/460	3	1.4-1.3/.65	60	48	1725	TEFC	D	No	B
AOF-20	1460	70	1/2	115/208-230	1	7.8/4.1-3.9	60	48	1725	TEFC	C	No	B
	1555	72	1/2	208-230/460	3	2.1-2./1.	60	48	1725	TEFC	D	No	B
AOF-25	2160	72	1/2	115/208-230	1	8/4.2-4	60	56	1140	TEFC	C	No	B
	2240	73	1/2	208-230/460	3	2.5-2.4/1.2	60	56	1140	TEFC	D	No	B
AOF-30	2990	75	1/2	115/208-230	1	8/4.2-4	60	56	1140	TEFC	C	No	B
	3100	76	1/2	208-230/460	3	2.5-2.4/1.2	60	56	1140	TEFC	D	No	B
AOF-35	Not Available				1	4-3.8/1.9	60	56	1140	TEFC	D	No	B
	4370	77	1	208-230/460	3	4-3.8/1.9	60	56	1140	TEFC	D	No	B
AOF-40	Not Available				1	4-3.8/1.9	60	56	1140	TEFC	D	No	B
	5450	79	1	208-230/460	3	4-3.8/1.9	60	56	1140	TEFC	D	No	B

*Published electrical ratings are approximate, and may vary because of motor brand. Actual ratings are on motor nameplate.

**Catalog dB(A) sound levels are at seven (7) feet. dB(A) sound levels increase by six (6) dB(A) for halving this distance and decrease by six (6) dB(A) for doubling this distance.

Explosion Proof Motors (Class I GP.D & Class II GP.F, G)*

Model	CFM	Sound dB(A)* at 7 FT	HP	Volts	Phase	Full Load Amps	HZ	Nema Frame	RPM	Type	Circuit	Thermal Overload	Bearing B-Ball
AOF-5	494	68	1/4	115/230	1	5.8/2.9	60	48	1725	FC	C	Yes	B
	494	70	1/4	208-230/460	3	1.4-1.3/.65	60	48	1725	FC	D	Yes	B
AOF-10	710	68	1/4	115/230	1	5.8/2.9	60	48	1725	FC	C	Yes	B
	710	70	1/4	208-230/460	3	1.4-1.3/.65	60	48	1725	FC	D	Yes	B
AOF-15	1015	69	1/4	115/230	1	5.8/2.9	60	48	1725	FC	C	Yes	B
	1015	71	1/4	208-230/460	3	1.4-1.3/.65	60	48	1725	FC	D	Yes	B
AOF-20	1555	70	1/2	115/230	1	7.8/3.9	60	48	1725	FC	C	Yes	B
	1555	72	1/2	208-230/460	3	2.1-2./1.	60	48	1725	FC	D	Yes	B
AOF-25	2240	72	1/2	115/230	1	8./4.	60	56	1140	FC	C	Yes	B
	2240	73	1/2	230/460	3	2.5-2.4/1.2	60	56	1140	FC	D	Yes	B
AOF-30	3100	75	1/2	115/230	1	8./4.	60	56	1140	FC	C	Yes	B
	3100	76	1/2	230/460	3	2.5-2.4/1.2	60	56	1140	FC	D	Yes	B
AOF-35 ▲	Not Available				1	3.8/1.9	60	56	1140	FC	D	No	B
	4370	77	1	230/460	3	3.8/1.9	60	56	1140	FC	D	No	B
AOF-40 ▲	Not Available				1	3.8/1.9	60	56	1140	FC	D	No	B
	5450	79	1	230/460	3	3.8/1.9	60	56	1140	FC	D	No	B

▲ = AOF 35 & 40, CL. 1, GP. D only **TEFC** = Totally enclosed, fan cooled **FC** = Fan cooled **C** = Capacitor start - Induction run **D** = Squirrel cage

*Published electrical ratings are approximate, and may vary because of motor brand. Actual ratings are on motor nameplate.

575 Volt Specifications

Model	CFM	Sound dB(A)** at 7 FT	HP	Volts	Phase	Full Load Amps	HZ	Nema Frame	RPM	Type	Circuit	Thermal Overload	Bearing B-Ball
AOF-5	494	70	1/4	575	3	.52	60	48	1725	TEFC	D	No	B
AOF-10	710	70	1/4	575	3	.52	60	48	1725	TEFC	D	No	B
AOF-15	1015	71	1/4	575	3	.52	60	48	1725	TEFC	D	No	B
AOF-20	1555	72	1/4	575	3	.80	60	48	1725	TEFC	D	No	B
AOF-25	2240	73	1/2	575	3	.88	60	56	1140	TEFC	D	No	B
AOF-30	3100	76	1/2	575	3	.88	60	56	1140	TEFC	D	No	B
AOF-35	4370	77	1	575	3	1.6	60	56	1140	TEFC	D	No	B
AOF-40	5450	79	1	575	3	1.6	60	56	1140	TEFC	D	No	B

*Catalog dB (A) sound levels at seven (7) feet. dB (A) sound levels increase by six (6) dB (A) for halving this distance, and decrease by six (6) dB (A) for doubling this distance.

C_v Viscosity Correction

Average Oil Temp °F	OIL					
	SAE 5 110 SSU at 100°F 40 SSU at 210°F	SAE 10 150 SSU at 100°F 43 SSU at 210°F	SAE 20 275 SSU at 100°F 50 SSU at 210°F	SAE 30 500 SSU at 100°F 65 SSU at 210°F	SAE 40 750 SSU at 100°F 75 SSU at 210°F	50-50 Ethylene Glycol & Water
100	1.14	1.22	1.35	1.58	1.77	1.11
150	1.01	1.05	1.11	1.21	1.31	1.02
200	.99	1.00	1.01	1.08	1.10	.96
250	.95	.98	.99	1.00	1.00	.95