

Electronic Temperature Control & Bulb Well Assembly (AC)

Part Number 86816

This is a line voltage single-stage electronic temperature control with single-pole, double-throw relay output and LED indication. It is designed with heating or cooling modes of operation, adjustable differential, and an interchangeable temperature sensor. The control couples electronic accuracy with remote sensing capability in a NEMA 1 high-impact plastic enclosure suitable for surface or DIN-rail mounting.

Pilot Duty Relay needed for 460V, not offered by Thermal Transfer Products.

67428 Temperature Control with NEMA 1 Enclosure

Dimensions Inches (mm)

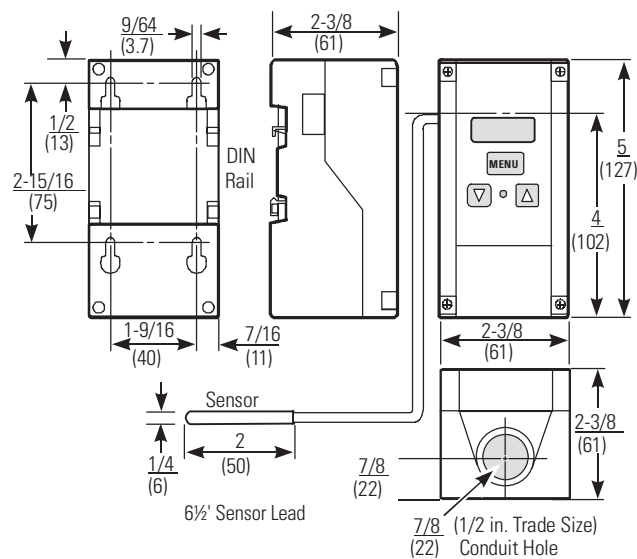

67429 Bulb Well

Dimensions Inches

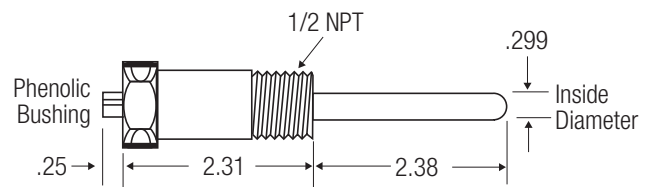

Specifications

Setpoint Range	-30°F to 212°F (-34°C to 100°C)			
Differential Range	1°F to 30°F (0.5°C to 17°C)			
Input Voltage	120 or 208/240 VAC, 50/60 HZ (1 Phase only)			
Current Draw	1.8 VA			
Relay Electrical Ratings	SPDT	120V NO (NC)	280V NO (NC)	240V NO (NC)
	Horsepower:	1 (0.25) HP	1 (0.33) HP	1 (0.5) HP
	Full Load Amps:	16 (5.8) A	9.2 (4.0) A	8.0 (4.9) A
	Locked Rotor Amps:	96 (3) A	55 (24) A	48 (29) A
	Non-Inductive Amps:	15 (10) A	10 (10) A	10 (10) A
Pilot Duty: 125 VA (NO) @ 24-240 VAC, 125 VA (NC) @ 120-240 VAC, 50 VA (NC) @ 24 VAC				
Sensor Type	Replaceable Thermistor with Reference Resistance of 2.25 K ohms at 77°F (25°C)			
Control Ambient Temperature	Operating: -30°F to 140°F (-34°C to 60°C) Shipping: -40°F to 185°F (-40°C to 85°C)			
Ambient Humidity	0 to 95% RH Non-Condensing, Maximum Dew Point: 85°F (29°C)			
Control Material	Case and Cover: NEMA 1 High Impact Lexan 950® Plastic.			
Agency Listings	UL Listed: File E27734, Guide XAPX (Temperature Indicating and Regulating Equipment) CSA Approved File LR948 Class 4813-02			

Lexan 950 is a registered trademark of the General Electric Company. The performance specifications are nominal.

Electronic Temperature Sensors

- Process connection: 1/4" NPT
- 2 switching outputs complementary hysteresis adjustable
- Measuring range of -13 - 284 °F (-25 - 140 °C)

Function

The unit generates 2 output signals: 1 x NO + 1 x NC with separately adjustable switch points (SET 1) and (SET 2).

OUT1

- With rising temperature OUT1 closes when the set value (SET1) is reached.
- With falling temperature OUT1 opens when the value (SET1) minus hysteresis is reached.

OUT2

- With rising temperature OUT2 opens when the set value (SET2) is reached.
- With falling temperature OUT2 closes when the value (SET2) minus hysteresis is reached.

The hysteresis is fixed at 5 K.

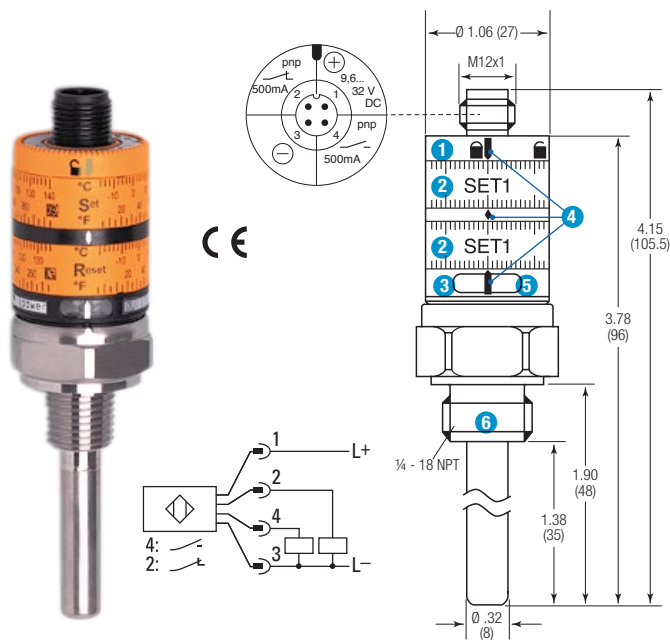

- 1 locking ring
 - 2 setting rings (manually adjustable after unlocking)
 - 3 LED yellow: lights if OUT1 = ON, temperature > [SET1]
 - 4 setting marks
 - 5 LED yellow: lights if OUT2 = ON, temperature < [SET2]
 - 6 process connection 1/4" NPT
- Pin 4 = OUT1 / Pin2 = OUT2

To obtain the setting accuracy, set both rings to minimum values, and then set desired values. All dimensions in inches (millimeters), unless noted otherwise.

Sensor Port Adapters

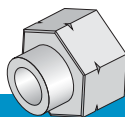

Part Number	Description
51627	#8SAE TO 1/2" BSPP
51653	#8 SAE TO 1/4" NPT
51654	#8 SAE TO 1/2" NPT

Technical Data

Application	Liquid and Gases
Electrical Design	DC PNP
Output	Normally open/closed complementary
Operating voltage (V)	9.6 - 32*
Current rating (mA)	500
Short-circuit protection	Yes (non-latching)
Reverse polarity protection	Yes
Overload protection	Yes
Voltage drop	< 2
Current consumption	< 30
Setting Range	
Set point, SP	3 - 284 / 37 - 543 °F (-16 - 140 / 3 - 284 °C)
Reset point, rP	-4 - 277 / 25 - 531 °F (-20 - 136 / -4 - 277 °C)
Adjustment of the switch point	Shims
Accuracy	
Setting accuracy	± 3 K
Repeatability	± 0.1 K
Temperature drift	0.1 / 10 K
Power-on delay time	0.5 s
Measuring element	1 x Pt 1000, to DIN EN 60751, class B
Dynamic response T05 / T09	1/3 s**
Minimum installation depth	.59 inches (15 mm)
Medium temperature	-13 - 257 °F (-25 - 125 °C) 293 °F (145 °C) max. 1 h
Ambient temperature	-13 - 158 °F (-25 - 70 °C)
Storage temperature	-40 - 257 °F (-40 - 212 °C)
Protection	IP 67, III
Shock resistance	DIN IEC 68-2-27:50 g (11 ms)
Vibration resistance	DIN EN 60068-2-6:20 g (10 - 2000 HZ)
EMC	EN 61000-4-2 ESD: 4 kV CD / 8 kV AD EN 61000-4-3 HF radiated: 10 V/m EN 61000-4-4 Burst: 2 Kv EN 61000-4-6 HF conducted: 10V
Housing materials	Stainless steel 316L / 1.4404; PC (Makrolon); PBT (Pocan); FPM (Viton)
Materials (wetted parts)	Stainless steel 316L / 1.4404
Display	Power: LED green; Switching status: LED yellow
Connection	M12 connector; gold-plated contacts
Weight	0.229 lbs (0.104 kg)

*Operating voltage "supply class 2" to cULus. ** According to DIN EN 60751
The values for accuracy apply to flowing water.

Optional Bulb Well

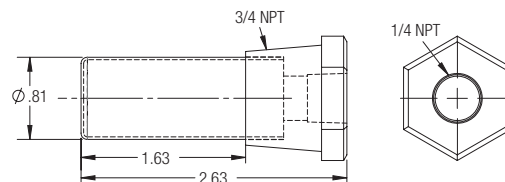

Part Number	Description
55857	Temperature Sensor, dual PNP outputs, 1/4" NPT
55858	Cover, Protective, PK
55859	4-wire Micro DC cordset, straight connector
51661 (Optional)	Bulb Well

Electronic Temperature Sensors

Low Cost, Simple Setup

Immersion thermostat, measuring temperature with a liquid filled sensing element. SPDT contacts, complete with waterproof protection pocket. Used to measure temperature on the primary heating pipe circuit, it is particularly suitable for automatic adjustment pumps.

- Contacts rating: 10(2,5)A/250V~
- Contacts: switching or closing contact for temperature increase
- Maximum head temperature: 176°F (80°C)
- Maximum bulb temperature: 257°F (125°C)
- Temperature rate of change: 1° K/min
- Protection degree: IP40

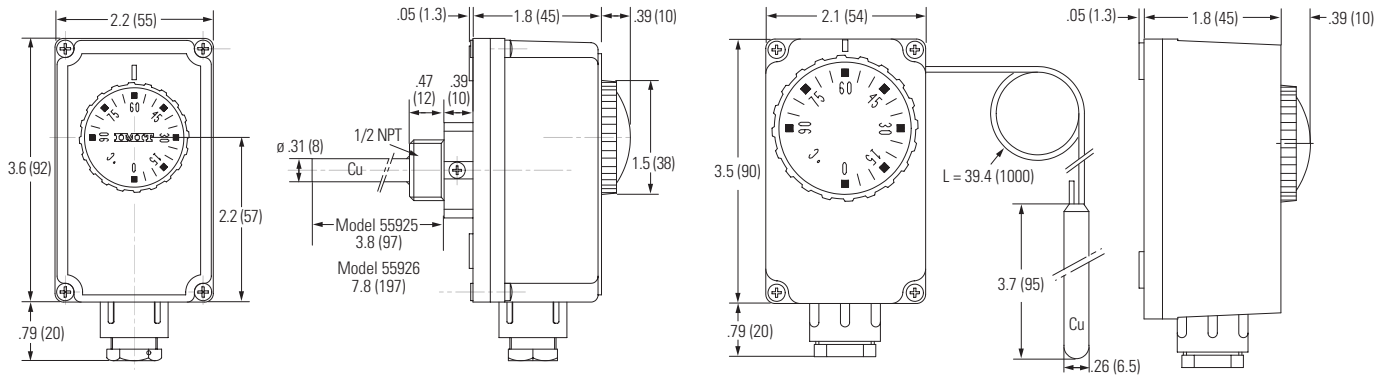

All dimensions in inches (millimeters), unless noted otherwise.

Part Number	Temperature Range	Differential	Maximum Bulb Temperature	Capillary Length	Protection Pocket 1/2" NPT	Copper Bulb
55925	0°/194°F (0°/90°C)	$\Delta t = 4 \pm 1K$	266°F (130°C)	NA	.27x.31x4" (7 x 8 x 100 mm)	NA
55926	0°/194°F (0°/90°C)	$\Delta t = 4 \pm 1K$	266°F (130°C)	NA	.27x.31x8" (7 x 8 x 200 mm)	NA
55927	0°/194°F (0°/90°C)	$\Delta t = 4 \pm 1K$	266°F (130°C)	39" (1000 mm)	NA	Ø .26x3.7" (6.5 x 95 mm)

Thermal Bypass Assembly

This thermal bypass valve is ideally suited for hydrostatic drive circuits which require fast warm-up, controlled fluid temperature, and low return line back pressure. When installed in the return line of a hydraulic circuit that employs an oil cooler, this device will modulate fluid temperature by either shifting return line flow through the cooler, or bypassing directly to the reservoir. In addition, a built-in pressure relief function automatically relieves excess pressure to the reservoir should the cooler become restricted and resultant pressure drop become too high for the cooler circuit.

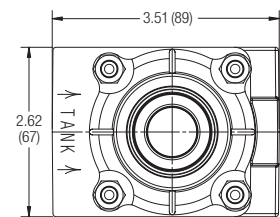
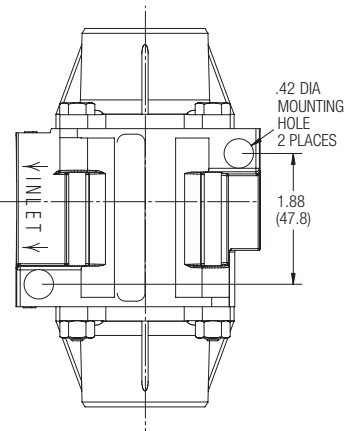
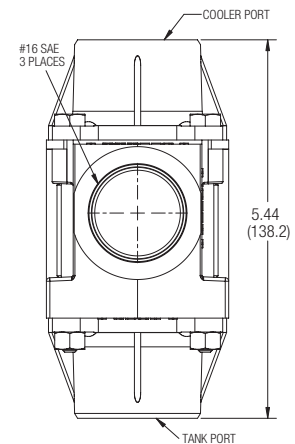

Standard Shift Temperatures

100°F (38°C) 120°F (49°C) 140°F (60°C) 160°F (71°C)

Full Shift (Cooler Port Open) Temperatures

Shift temperature plus 25°F (14°C)

Relief Valve Setting 65 PSI (4.5 BAR) *Consult factory for other pressure settings.*

Maximum Operating Pressure 250 PSI (17 BAR)

Proof Pressure 300 PSI (21 BAR)

Minimum Burst Pressure

Up to the full shift temperature: 325 PSI (22 BAR).

Above the full shift temperature: 600 PSI (41 BAR).

Minimum Operating Temperature -30°F (-34°C)

Maximum Operating Temperature Shift temperature plus 75°F (24°C)

Maximum Flow Rating 60 GPM (227 l/m)

Leakage @ 250 PSI (17 BAR) and 60 GPM (227 l/m) Inlet Flow

Cooler Port:

- 0.5 GPM (2 l/m) maximum up to 5°F (3°C) before shift temp.
- 1.0 GPM (4 l/m) maximum from 5°F (3°C) before shift to shift.

Tank Port: 0.10 GPM (0.4 l/m) maximum

Operating Fluid Mineral base hydraulic fluids

Construction Aluminum die-cast housing

Operating Characteristics

- Mode 1: At temperatures below the shift temperature oil flows from inlet to tank port.
- Mode 2: At temperatures between the start of shift and full shift the flow from the inlet port is divided between the cooler and tank ports.
- Mode 3: At temperatures above the full shift temperature inlet flow is through the cooler port.
- Mode 4: At temperatures above the full shift temperature the excess pressure is relieved through the tank port.

For 120°F Shift Temperature

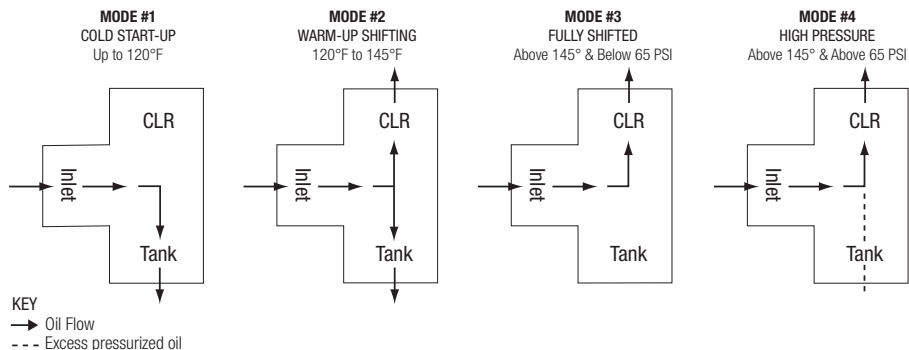

NOTE: If the temperature drops below 145°F the valve will shift back to modes 2 or 1.

Graphic Symbol

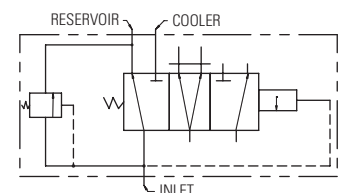

Thermal Bypass Assembly

Pressure Drop (Mobile DTE 26 OIL)

Inlet Port Thru Tank Port
@ 100°F (38°C) (300 SUS)

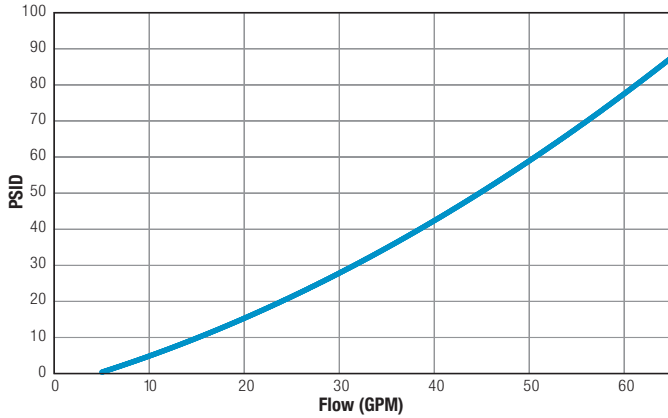

Inlet Port Over Integral Relief Valve
@ 170°F (77°C) (78 SUS)

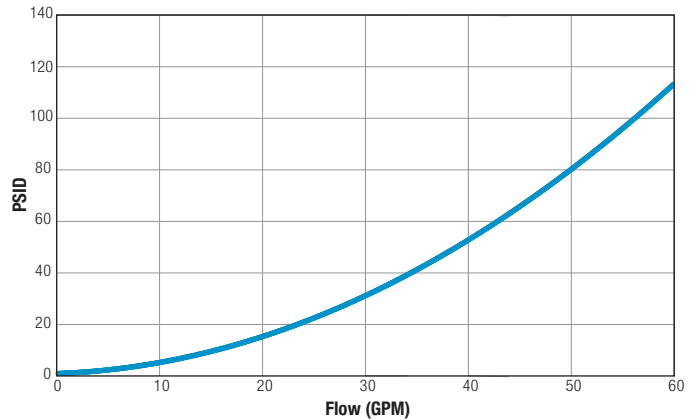

Inlet Port Thru Cooler Port
@ 145°F (63°C) (110 SUS)

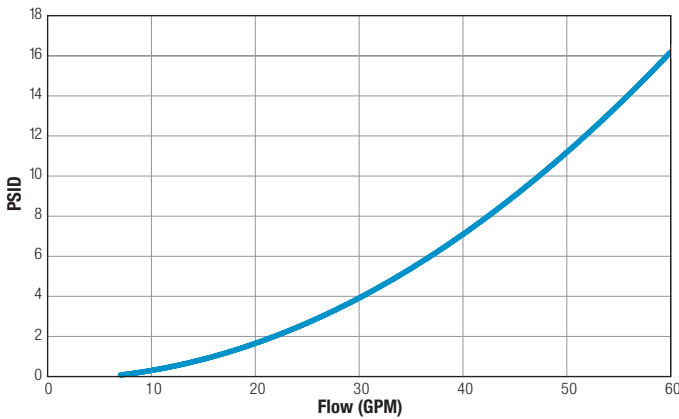

NOTE: Pressure drop shown is added to relief valve crack pressure for total pressure drop.

Part Number	Shift Temperature
65654	100°F (38°C)
65655	120°F (49°C)
65656	140°F (60°C)
65657	160°F (71°C)

How to Order Consult factory for pricing and lead time

- - Thermal Bypass Assembly

Part Number

Pressure Setting
 65 = Standard, 65 PSI
 Optional pressure settings available in 5 PSI increments, up to 85 PSI.

Three-Way Thermostatic Valves

1/2", 3/4", 1", 1 1/2" & 2" NPT Ports*

- Self-contained
- Wide range of temperatures
- Rugged construction
- Non-adjustable
- Heavy duty
- Operate in any position
- Tamper-proof
- Replaceable element
- Compact



Materials

Housing Grey iron (steel or bronze optional)
125 PSI maximum operating pressure

O-Ring Seals Viton (Buna N optional)

*3", 4" and 6" Flange Models also available.

Operation

TTP thermostatic valves use the principle of expanding wax. A self-contained power element activates a stainless steel sliding valve that provides a positive three-way valve action. All temperature settings are factory set. Elements are field replaceable to obtain the same, or a new bypass temperature setting.

On starting, total flow is in the bypass mode. As the fluid temperature rises, some fluid is diverted to the cooling system. As fluid temperature continues to rise, more flow is diverted until the valve is fully stroked. At this point, all the flow is diverted to the cooler. With respect to temperature ranges, the "nominal" temperature represents the "operating temperature."

Valves are acceptable for oil or water service.

Applications

Three Way Thermostatic Valves may be installed for either mixing or diverting modes of operation at the preference of the user. They may be mounted in any plane.

When installed as a mixing valve, it is on the cold side of the application, and mixes hot liquid with cooled liquid to discharge the proper temperature fluid to the process.

When installed as a diverting valve, it is on the hot side of the application, and bypasses the cold liquid allowing the system to warm up, then directs the hot liquid to the cooler.

Temperature settings are nominal. 110°F and 140°F are standard. Other settings are available upon request. The valves begin to "shift" (open) about 10°F below the nominal temperature setting and are fully shifted about 10°F above.

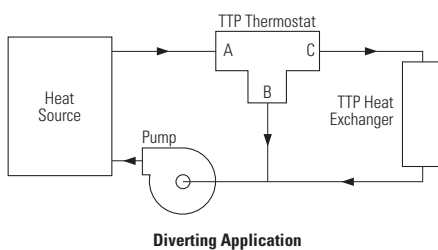
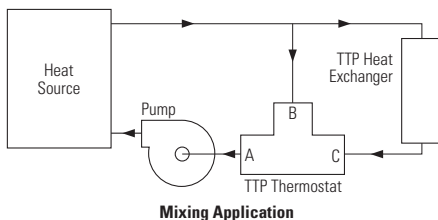

Typical Installation

Hydraulic Power Units Diverting mode 110°F

Air Compressors Mixing mode 140°F

Mobile Oil Coolers Diverting mode 110°F

Radiators Diverting mode 190°F

Three-Way Thermostatic Valves

Pressure Drop Curves

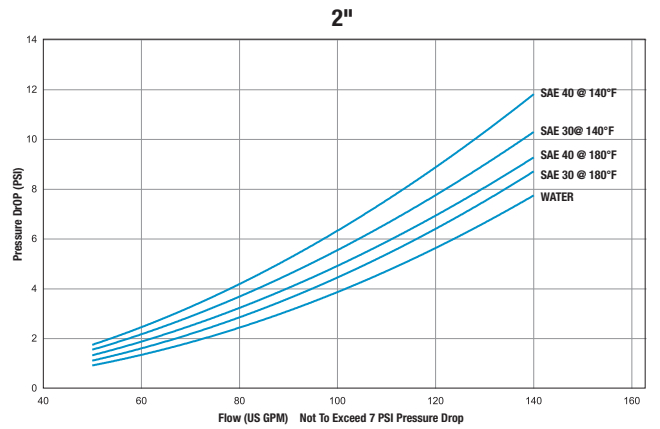
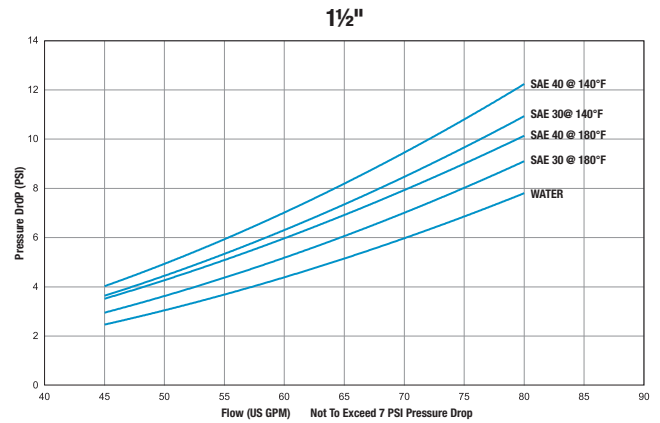
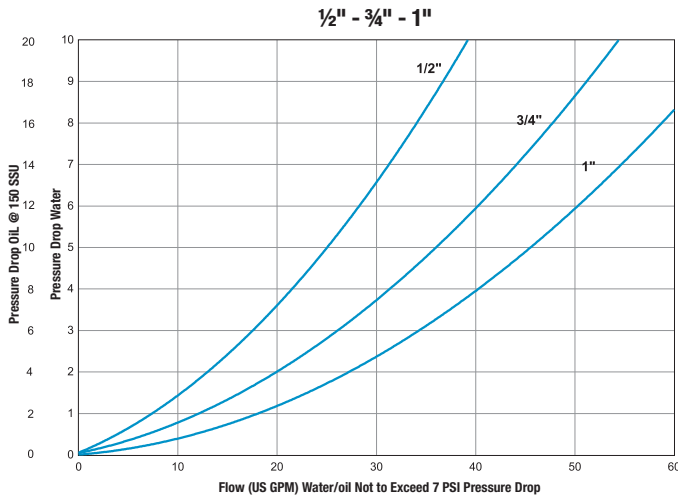

Dimensions and Part Numbers

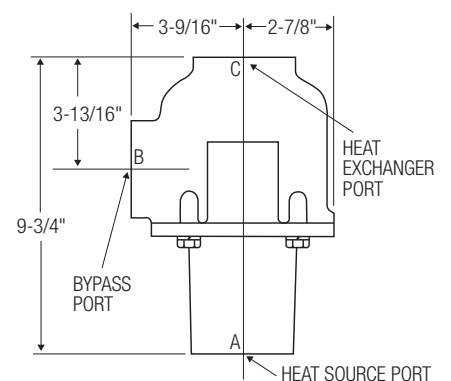
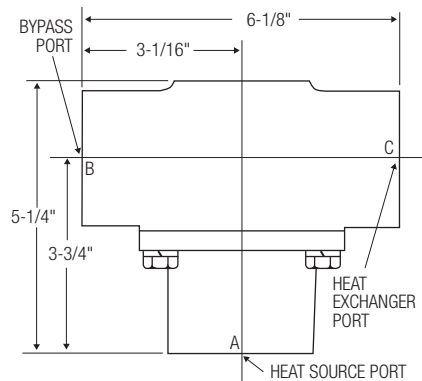
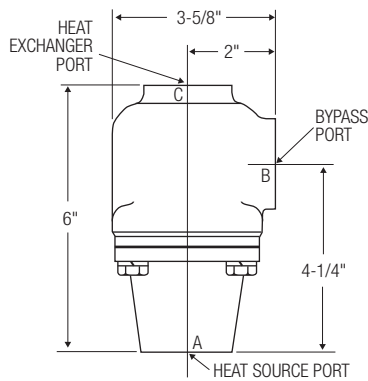

Port Size	Part Number
1/2" NPT	66037-110°F
1/2" NPT	66037-140°F
3/4" NPT	66038-110°F
3/4" NPT	66038-140°F
1" NPT	66039-110°F
1" NPT	66039-140°F
#16 SAE	67365-110°F
#16 SAE	67365-140°F

Port Size	Part Number
1 1/2" NPT	66040-110°F
1 1/2" NPT	66040-140°F
#24 SAE	67760-110°F

Port Size	Part Number
2" NPT	66041-105°F
2" NPT	66041-140°F

NOTE: All three ports on any one valve have the same thread size.

Three-Way Thermostatic Valves

Special Temperature Ranges

½" - ¾" - 1" NPT Part Numbers	1½" NPT Part Numbers	2" NPT Part Numbers
65974	65977	65978
65975	66040	66041
65976	67760	
66037	(#24 SAE)	
66038		
66039		
67365		
(#16 SAE)		

½" - ¾" - 1" NPT		1½" NPT		2" NPT	
Nominal	Temperature Range (°F)	Nominal	Temperature Range (°F)	Nominal	Temperature Range (°F)
80	77-88	80	70-88	75	70-85
90	80-100	90	80-100	90	85-105
110	100-120	110	100-120	105	100-116
120	110-130	120	110-130	120	110-130
130	120-140	130	120-140	130	124-140
140	130-150	140	130-150	140	135-150
150	140-160	150	140-160	150	145-160
160	150-170	160	150-170	155	150-165
170	163-180	170	163-180	160	155-172
185	175-190	175	170-185	165	160-175
195	185-200	180	175-190	170	165-180
200	190-210	190	185-200	180	175-190
		200	190-210	195	188-208
				210	200-215

EXAMPLE: 1" NPT, Part Number 66039-90 indicates the 1" NPT valve with a nominal shift temperature of 90°F. The actual operating temperature range in this example is 80-100°F. The valve begins to open at 80°F, and is fully open at 100°F.

How to Order Consult factory for pricing and lead time

					-				°F
Valve Part Number						Nominal Temperature Setting			