

Piping Hook-up

A Series

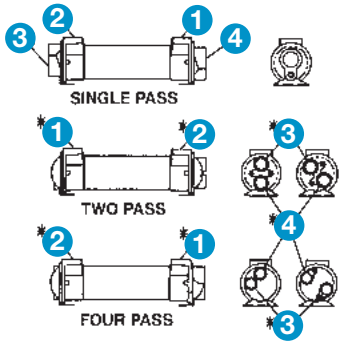

B Series

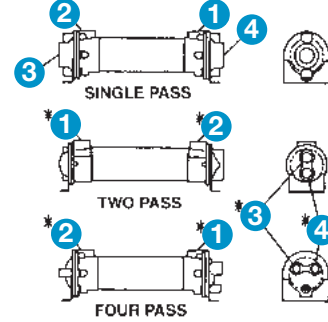

HC / SSC / EC Series

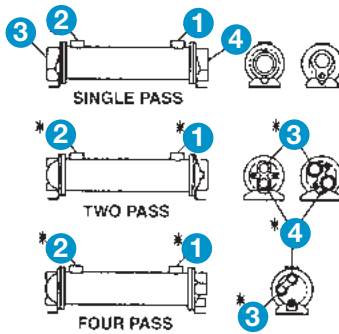

SLE / SL / R Series

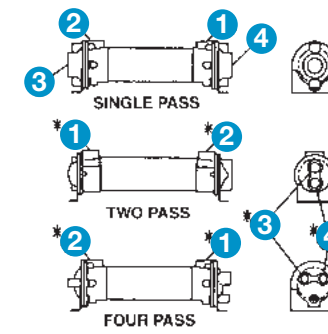

EC bonnet rotation is slightly different from what is shown. See Series literature for details.

EK / EKS / EKM Series

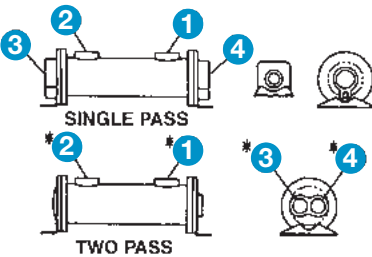

K / KN Series

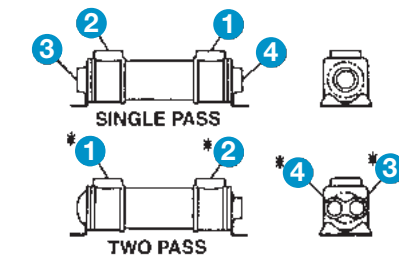

U / UC / UR Series

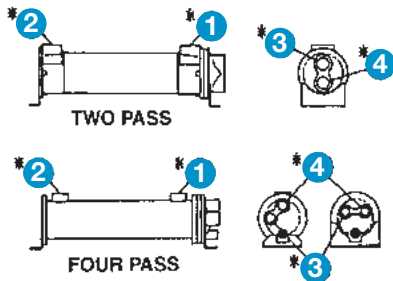

Note baffle location when inserting bundle into shell assembly after cleaning.

- 1** Hot Fluid In
- 2** Cooled Fluid Out
- 3** Cooling Water In
- 4** Cooling Water Out

*Note: For all two pass and four pass heat exchangers: connections **1** and **2** may be reversed, and connections **3** and **4** may be reversed with no effect on performance.

Installation

The satisfactory use of this heat exchange equipment is dependent upon precautions which must be taken at the time of the installation.

1. Connect and circulate the hot fluid in the shell side (over small tubes) and the cooling water in the tube side (inside small tubes). Note piping diagrams.
2. If an automatic water regulating valve is used, place it on the INLET connection of the cooler. Arrange the water outlet piping so that the exchanger remains flooded with water, but at little or no pressure. The temperature probe is placed in the hydraulic reservoir to sense a system temperature rise. Write the factory for water regulating valve recommendations.
3. There are normally no restrictions as to how this cooler may be mounted. The only limitation regarding the mounting of this equipment is the possibility of having to drain either the water or the oil chambers after the cooler has been installed. Both fluid drain plugs should be located on the bottom of the cooler to accomplish the draining of the fluids. Drains are on most models.
4. It is possible to protect your cooler from high flow and pressure surges of hot fluid by installing a fast-acting relief valve in the inlet line to the cooler.
5. It is recommended that water strainers be installed ahead of this cooler when the source of cooling water is from other than a municipal water supply. Dirt and debris can plug the water passages very quickly, rendering the cooler ineffective. Write the factory for water strainer recommendations.
6. Fixed bundle heat exchangers are generally not recommended for steam service. For steam applications, a floating bundle exchanger is required. Note: When installing floating bundle unit, secure one end firmly and opposite end loosely to allow bundle to expand and contract. Consult factory for selection assistance.
7. Piping must be properly supported to prevent excess strain on the heat exchanger ports. If excessive vibration is present, the use of shock absorbing mounts and flexible connectors is recommended.

Service

Each heat exchanger has been cleaned at the factory and should not require further treatment. It may be well to inspect the unit to be sure that dirt or foreign matter has not entered the unit during shipment. The heat exchanger should be mounted firmly in place with pipe connections tight.

Caution

If sealant tape is used on pipe threads, the degree of resistance between mating parts is less, and there is a greater chance for cracking the heat exchanger castings. Do not overtighten. When storing the unit, be sure to keep the oil and water ports sealed. If storage continues into cold winter months, the water chamber must be drained to prevent damage by freezing.

Performance information should be noted and recorded on newly installed units so that any reduction in effectiveness can be detected. Any loss in efficiency can normally be traced to an accumulation of oil sludge, or water scale.

Recommendations

Replace gaskets when removing end castings. It is recommended that gaskets be soaked in oil to prevent corrosion and ensure a tight seal.

Salt water should not be used in standard models. Use salt water in special models having 90/10 copper-nickel tubes, tube sheets*, bronze bonnets and zinc anodes on the tube side. Brackish water or other corrosive fluids may require special materials of construction.

When zinc anodes are used for a particular application, they should be inspected two weeks after initial startup.

At this time, by visual inspection of the anode, determination of future inspection intervals can be made, based on the actual corrosion rate of the zinc metal.

The zinc anodes must be replaced when 70% of the zinc volume has been consumed.

It may be necessary to drain the water chambers of the exchanger to protect it from damage by freezing temperatures. Drains are provided in most standard models.

The oil chamber of the exchanger may become filled with sludge accumulation and require cleaning. It is recommended that the unit be flooded with a commercial solvent and left to soak for one-half hour. Backflowing with the solvent or regular oil will remove most sludge. Repeated soaking and backflowing may be required, depending on the degree of sludge buildup.

It may be necessary to clean the inside of the cooling tubes to remove any contamination and/or scale buildup. It is recommended that a fifty-fifty percent solution of inhibited muriatic acid and water may be used. For severe problems, the use of a brush through the tubes may be of some help. Be sure to use a soft bristled brush to prevent scouring the tube surface causing accelerated corrosion. Upon completion of cleaning, be certain that all chemicals are removed from the shellside and the tubeside before the heat exchanger is placed into service.

When ordering replacement parts or making an inquiry regarding service, mention model number, serial number, and the original purchase order number.

**Available on HC/SSC/SSCA Series models only.*

Maximum Shell & Tube Flow Rates

CAUTION

Incorrect installation can cause this product to fail prematurely, causing the shell side and tube side fluids to intermix. Maximum allowable flow rates are as charted below.

B Series Model No. Example: B-702-A4-F

Unit Size	Shell Side (GPM) / Baffle Spacing					Tube Side (GPM)		
	A	B	C	D	E	O	T	T
400	9.6	—	—	—	—	25		
700	17	29	29	—	—	61	31	15
1000	24	48	69	69	—	146	73	37
1200	29	57	115	115	—	224	112	56
1600	37	75	149	253	—	363	181	91
2000	—	—	187	347*	457*	652	326	163

*281 GPM maximum for all B-2005-D **500 GPM maximum for all B-20080-E and 562 GPM maximum for all B2006-E6 or B-2006-E10
562 GPM maximum for all B-2006-E6 or B-2006-E10

A Series Model No. Example: A-1024-2-6-F

Unit Size	Baffle Spacing	Shell Side (GPM)	Tube Side (GPM)		
			O	T	F
SA-400	.75	7	18	—	—
	2	19			
600	1	14	48	24	12
	1.5	21			
	2	29			
800	4	29	87	43	21
	1.5	29			
	2	38			
1000	3	57	146	73	37
	4	69			
	1.5	32			
	2	42			
1200	3	60	224	112	56
	4	69			
	2	51			
	3	77			
1600	4	103	280	203	101
	6	115			
	26	66			
	3	100			
	4	133			
	6	200			

HC / SSC Series Model No. Example: HC-1024-2-6-F

Unit Size	Baffle Size	Shell Side (GPM)	Tube Side (GPM)		
			O	T	F
600	1.38	19	48	24	12
	2	29			
	3	29			
800	1.38	26	84	42	21
	1.7	31			
	2	38			
	3	57			
1000	4	69	146	23	37
	1.38	24			
	2	41			
	3	64			
1200	5	69	224	112	56
	2.5	60			
	3	77			
	3.62	93			
1700	5	115	465	232	116
	6	115			
	3.	125			
	4	143			
	4.5	161			
	5	179			
	6	215			
7	251				
	8.4	253			

EC Series Model No. Example: EC-1236-6-F

Unit Size	Baffle Size	Shell Side (GPM)	Tube Side (GPM)		
			O	T	F
1000	4	55	66	33	15
	6	70			
	8	70			
1200	4	65	120	60	28
	6	100			
	8	115			
	12	115			
1700	4	90	220	110	52
	6	140			
	8	190			
	12	255			

K / EK Series Model No. Example: EK or K-712-F

Unit Size	Shell Side (GPM)	Tube Side (GPM)	
		O	T
500	20	13	—
100	70	24	12
1000	100	56	28