

## General Information

1. Air cooled aftercoolers are built for operation with maximum air pressure of 250 PSI and temperature of 350°F.
2. The motors furnished are built for fan duty. Consideration should be given to the installation location so motors **are not subjected to extreme temperatures.**
3. Air cooled aftercoolers are generally installed at floor level. If the unit is to be used to reclaim waste heat for space heating, it is recommended that the unit be mounted 7 to 14 feet above the floor, depending on the structure, for proper heat distribution.

## Installation

1. Air cooled aftercoolers are designed for mounting either by mounting legs, or by suspension from brackets attached to the cabinet. (Hanger rod not included.)
2. Aftercoolers should **not** be located in corrosive atmospheres as rapid deterioration of casing, cooling coil, fan and motor may take place resulting in reduced life.
3. Piping should be sized based on air flow and pressure drop requirements and not on the aftercooler's supply and return connection size. The piping must also be properly supported to prevent manifold stress.
4. A strainer located ahead of the aftercooler should be installed to trap scale, dirt or sludge that may be present in piping and equipment, or that may accumulate with use.
5. A separator/trap/drain should be installed in the outlet piping of the aftercooler to remove condensate. Condensate could damage the cooler if condensate is allowed to freeze.
6. Flexible connectors should be installed to prevent the stressing of manifolds. (Must be properly installed to validate warranty.)
7. Arrange the outlet pipe so that the moisture that condenses within the aftercooler can drain freely by gravity.
8. For proper air flow, a minimum of 12" clearance should be allowed between the aftercooler fan and any wall or obstructions.

## Electrical

1. **CAUTION To prevent possible electrical shock, it is important to properly ground this unit using grounding screw provided. Be sure not to disconnect the motor grounding wire when making this connection.**
2. Connect motor only to a power supply of the same characteristics as shown on the motor nameplate. Be sure to provide proper fusing to prevent possible motor burnout. Before starting motor, follow manufacturer's recommendations. Turn fan manually to eliminate possible motor burnout in the event the fan has been damaged in shipment. Observe operation after motor is started for the first time.
3. In a typical compressor aftercooler installation, the aftercooler is interlocked to the compressor so it runs whenever the compressor is turned on.

## Maintenance

Inspect the unit regularly for loose bolts and connections, rust and corrosion, and dirty or clogged heat transfer surfaces (cooling coil).

## Heat Transfer Surface

Dirt and dust should be removed by brushing the fins and tubes and blowing loose dirt off with an air hose. Should the surface be greasy, the motor should be removed and the fins and tubes brushed or sprayed with a non-flammable degreasing fluid. Follow with a hot water rinse and dry thoroughly. A steam hose may also be used effectively.

## Casing, Fan and Motor

Dirt and grease should be removed from these parts. Rusty or corroded surfaces should be sanded clean and repainted.

## Internal Cleaning

Once a year piping should be disconnected and a degreasing agent or flushing oil circulated through the unit to remove sludge from turbulators and internal tube surfaces to return the unit to full capacity. A thorough cleaning of the entire system in the same manner is preferable to avoid carry-over from uncleaned piping, pump and accessories. The strainer of any filtering devices should be removed and serviced following this cleaning operation. **Caustic cleaners should not be used to clean these heat exchangers.**

## Motor

Keep outside surface free of dirt and grease so motor will cool properly. Make sure cooling air over motor is not obstructed. Sleeve bearing motors are normally furnished and require lubrication every 6 months. Add a few drops of SAE 20 oil to each bearing. When TEFC Motors are furnished, they are normally prelubricated ball bearing motors and require no grease for about 5 to 10 years.

## Repair or Replacement of Parts

When ordering replacement parts or making inquiry regarding service, mention model number, serial number and the original purchase order number. Any reference to the motor must carry full nameplate data.

# UPA50 / UPA 100 Leg Installation

Vertical Air Flow Leg Installation

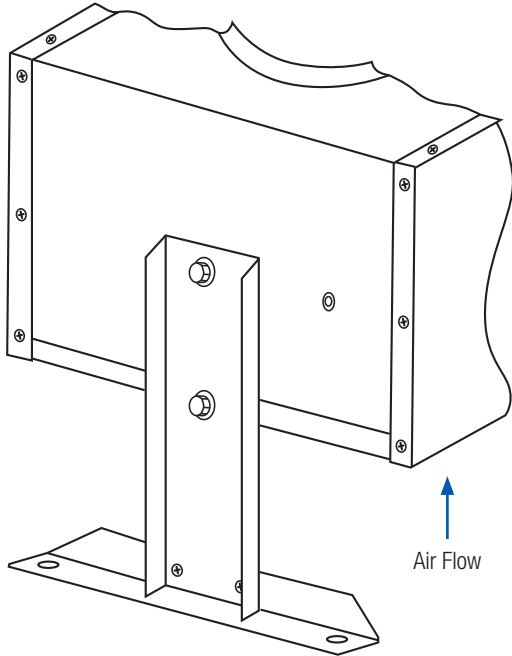

Horizontal Air Flow Leg Installation

